



Silt Protector

Installation
Caution
Maintenance

Basic Installation Guide

Silt Protector
Flot & Curtain
part

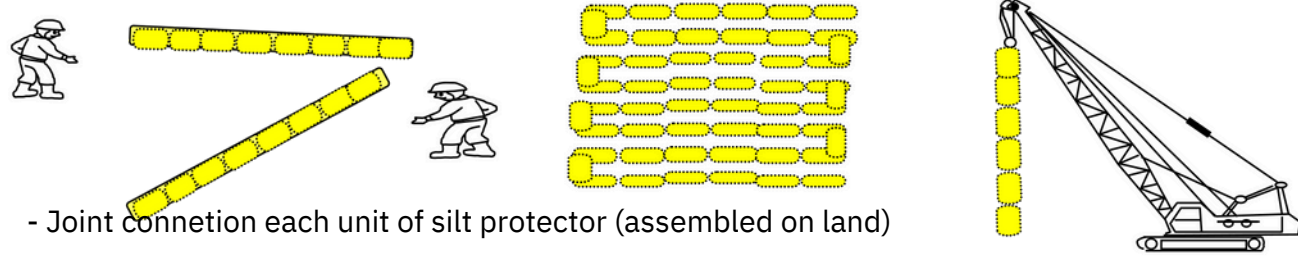

Silt Protector
Tonbag
Anchor

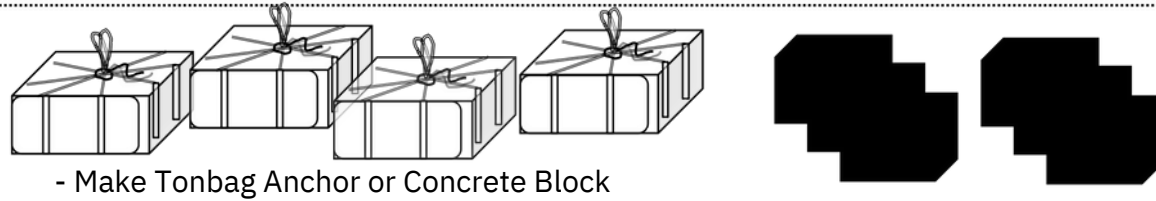

Loading
&
move

- Loading on to barge and move to where you want to install

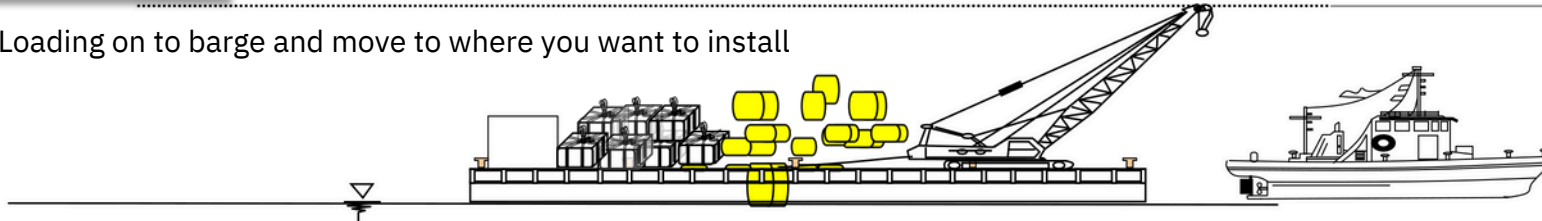

Installation

- Connect Tonbag anchor to the unit

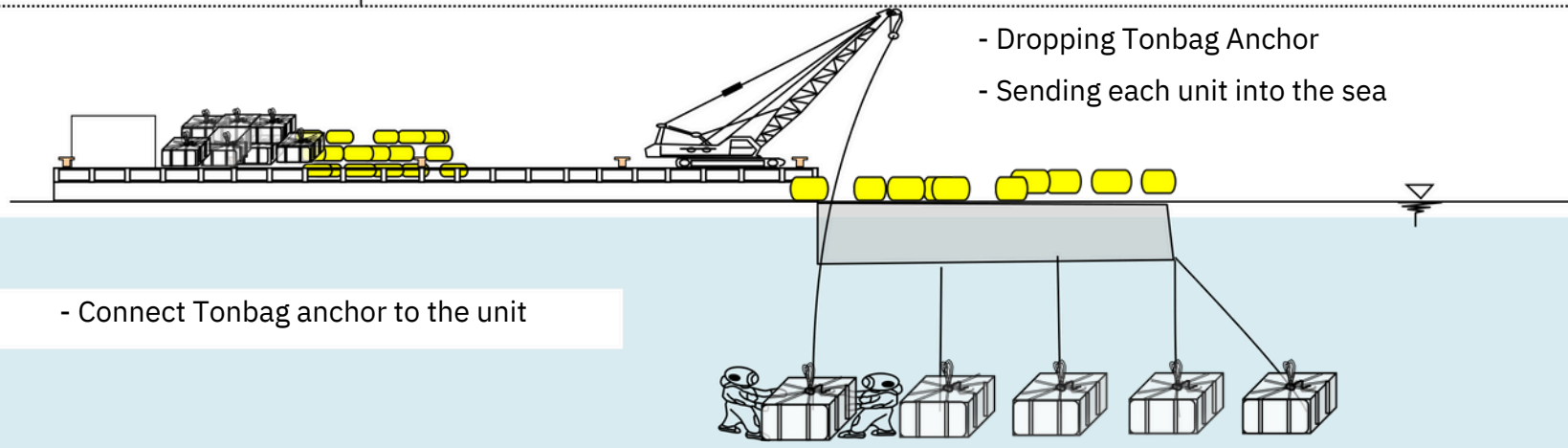

Installation Guide (Temporary tying curtains)

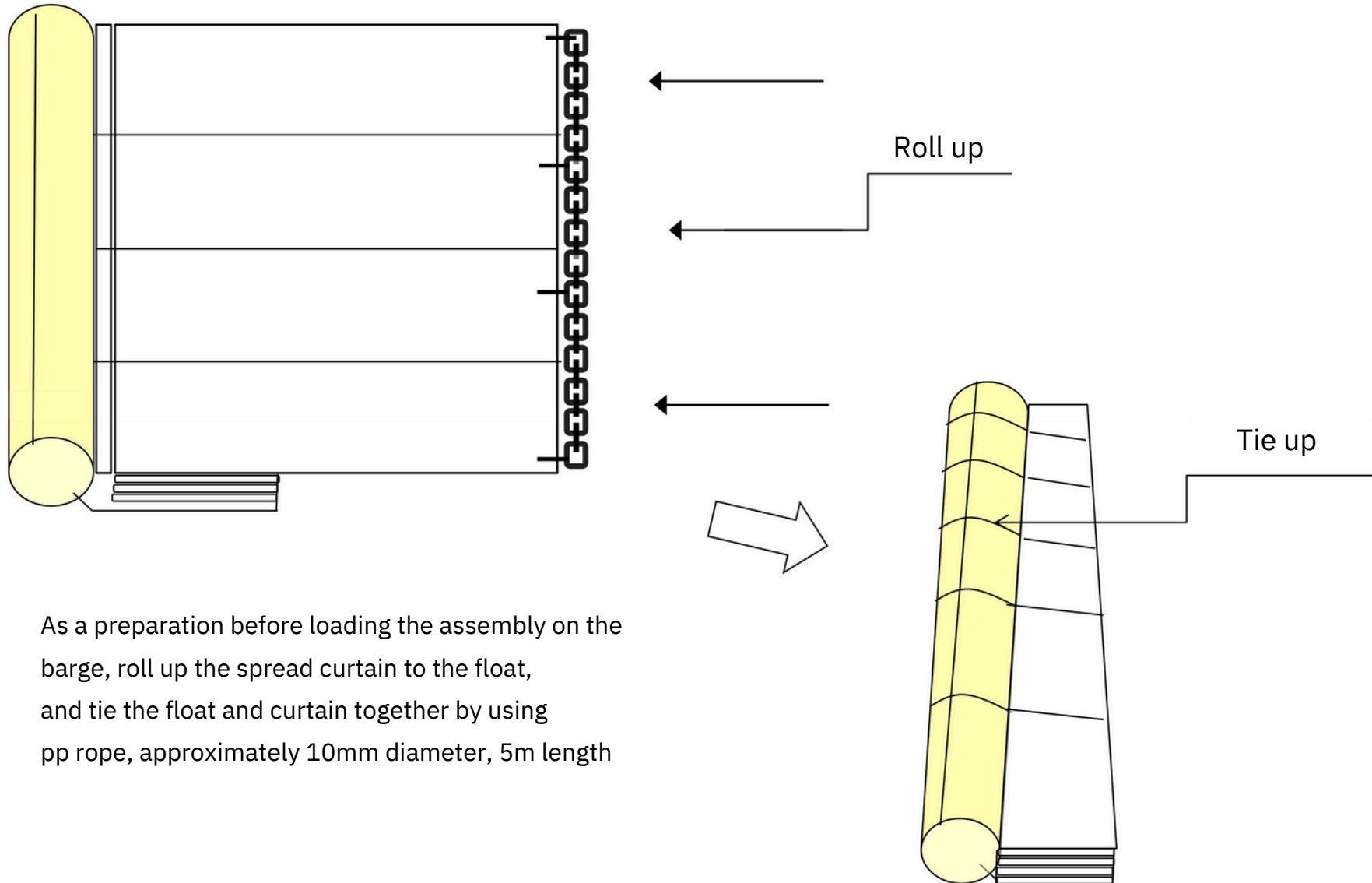

As a preparation before loading the assembly on the barge, roll up the spread curtain to the float, and tie the float and curtain together by using pp rope, approximately 10mm diameter, 5m length

Installation Guide (Connecting Curtain and Anchor)

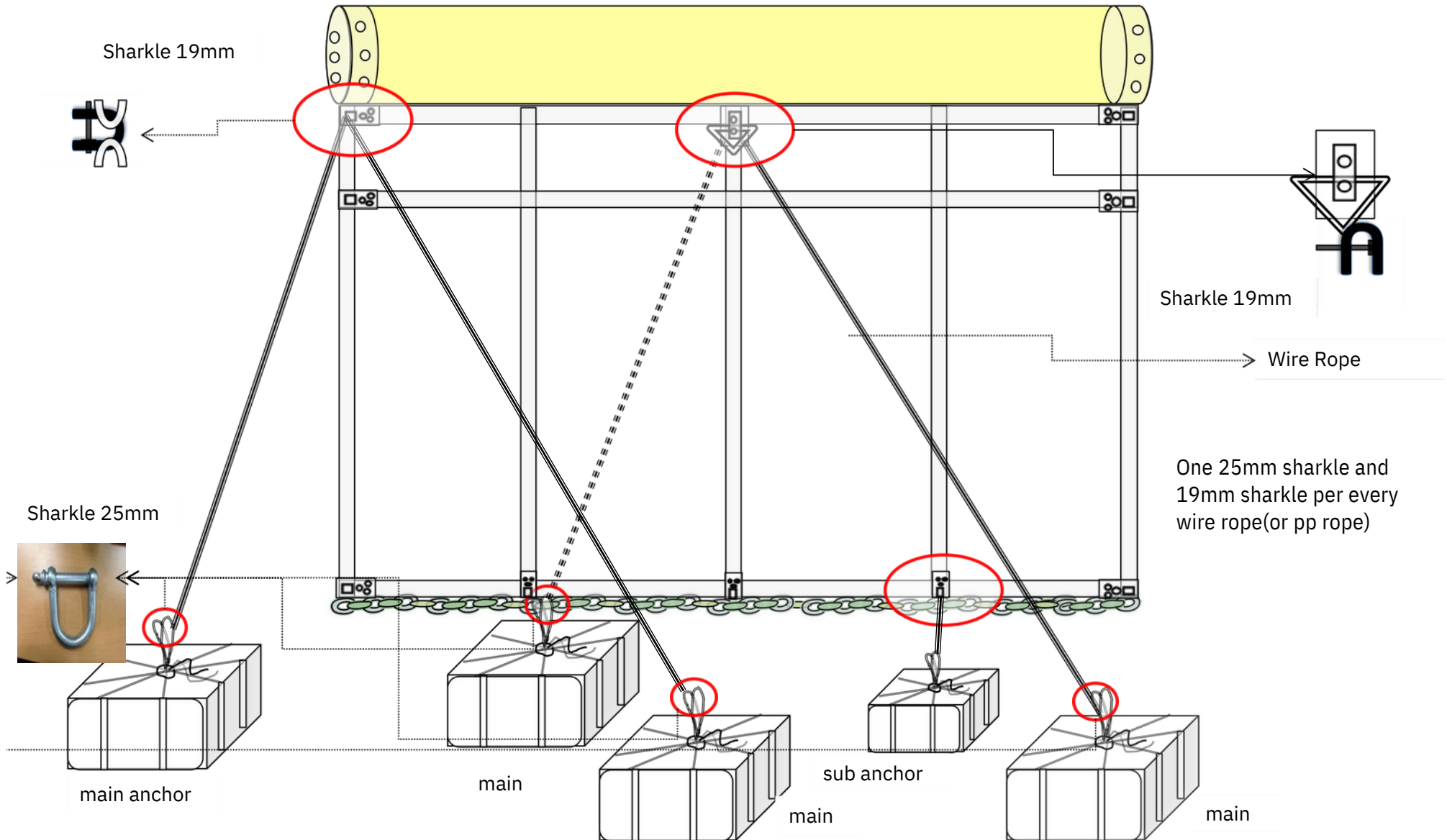

Caution

Designate a person who is in charge of management of the Silt Protector. If an environment that exceeds the design conditions is estimated, remove the Silt Protector immediately, or the unit may be damaged. If the Silt Protector requires a repair, take necessary actions soon. If it is left without being repaired, the function of the unit may be affected adversely or the damage may expand so that it cannot be repaired.

If the Silt Protector has been dislocated from the proper position or the layout has been deformed, restore it to original position or formation immediately. Otherwise, serious accident may be caused.

Be careful not to damage the float and curtain when removing sea shells and plants from these components.

The float is made of Styrofoam which is inflammable. Keep fire away from this component.

Preconditions for maintenance

This Silt Protector has been designed based on the precondition that it must be removed in environmental conditions that exceed the design condition. Therefore, in case it was not removed in such condition, it must be inspected after such environmental condition has ended, and must be repaired as soon as possible if necessary.

Check the unit periodically, and any component that have been deteriorated due to aging must be repaired or replaced with new. Table 1 presents the conditions on which this Silt Protector is designed.

Table 1 Design conditions

Item	Condition	Item	Condition
Speed of wind	m/second	Diameter float	m
Speed of current	m/second	Length of curtain	months
Wave Height	m/second	Serviceable life	H.W.L +
Period of wave	Seconds	Range of tide	m
Wave length	m	Sediment	L.W.L . .m
Depth of water	m		

Maintenance 1

Daily inspection

The Silt Protector should be visually monitored by patrol during the period it is placed in the water. The patrol is performed on the boat for the purpose of preventing ships from running against the unit and of finding abnormality in earlier phase. (once per day)

Caution:In case the Silt Protector has a serious trouble, Failure to do the daily check may cause serious trouble in addition to the loss of its normal pollution protection performance.

Periodic inspection

In addition to visual inspection on the boat, periodically dive to check the unit thoroughly. (Once per every three months)

Caution:In case the Silt Protector has been damaged, failure to do the periodical check may cause the loss of its normal pollution protection performance and a damage that cannot be repaired to occur.

Extra inspection

After typhoon or other abnormal weather, check the unit for the purpose of finding possible damages or troubles earlier. This check is performed basically on the boat, but dive to check the unit if necessary.

Caution:In case the Silt Protector has been seriously damaged, failure to do the extra check may cause the loss of its normal pollution protection performance and a damage that cannot be repaired to occur.

Sea shell removal

If it is found that the freeboard of the float is less than 1/2 of its diameter due to increase of the total weight with the growth of sea shells and plants on the float and curtain, dive to clean these components. It is recommended to monitor the change of the freeboard of the float. Check it at the periodical inspection, and record the growth of the sea organisms. (perform these works as necessary.)

Caution:Failure to do the cleaning may increase the weight of the Silt Protector resulting in sinking it to cause loss of the function. Be careful not to damage the Silt Protector when cleaning the unit.

Maintenance 2

Flow of maintenance works

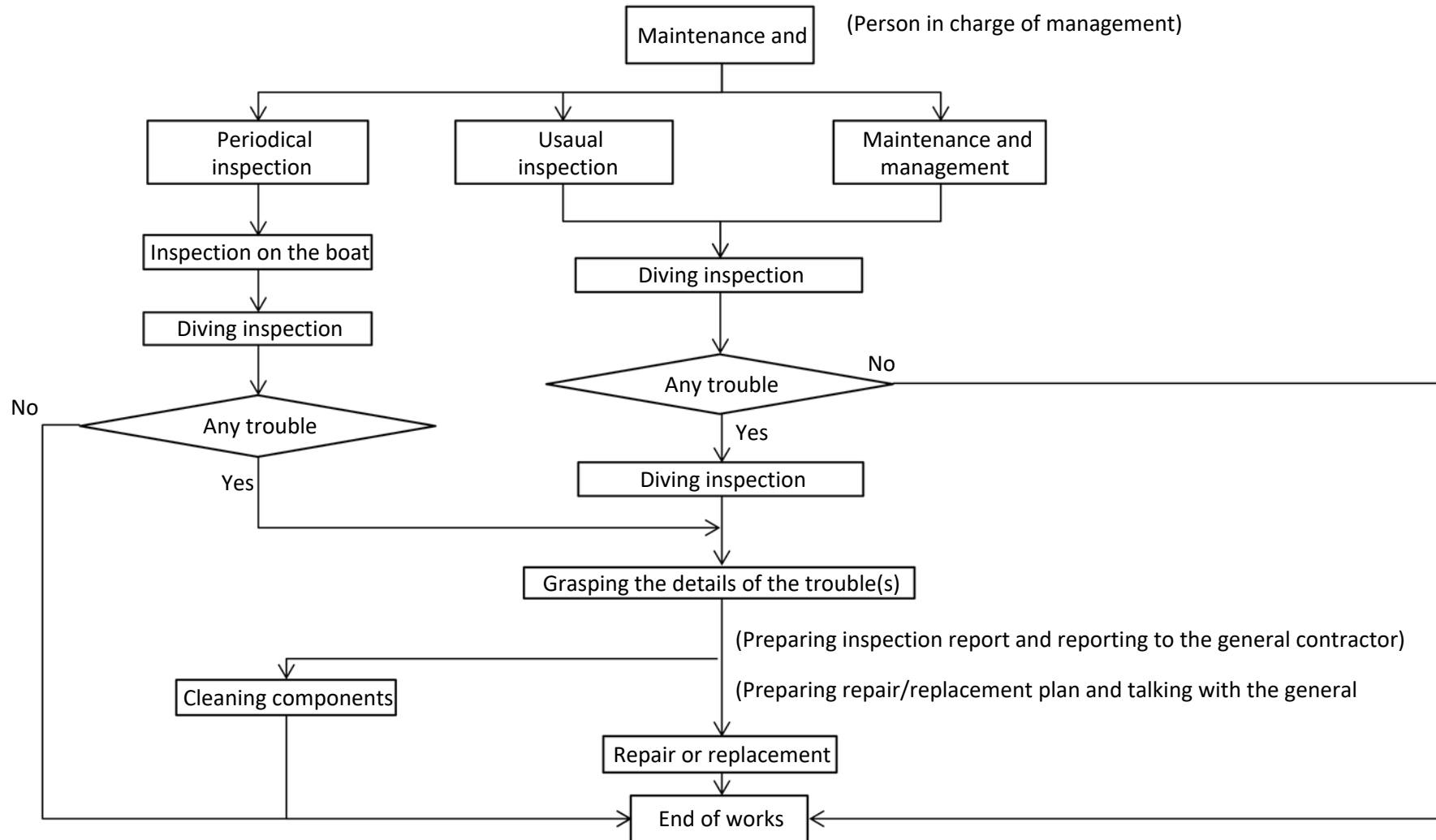

Components

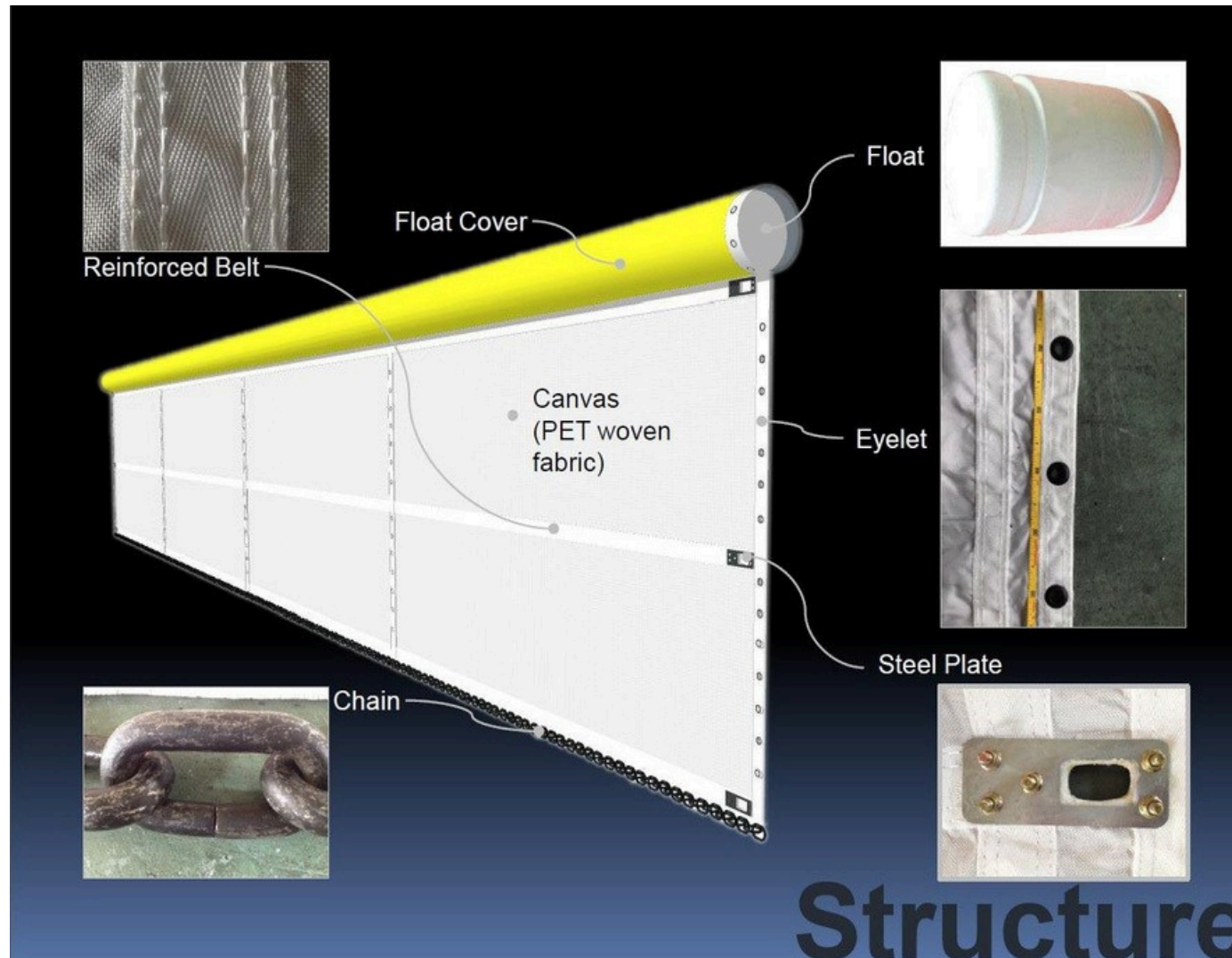

Anchor system

