

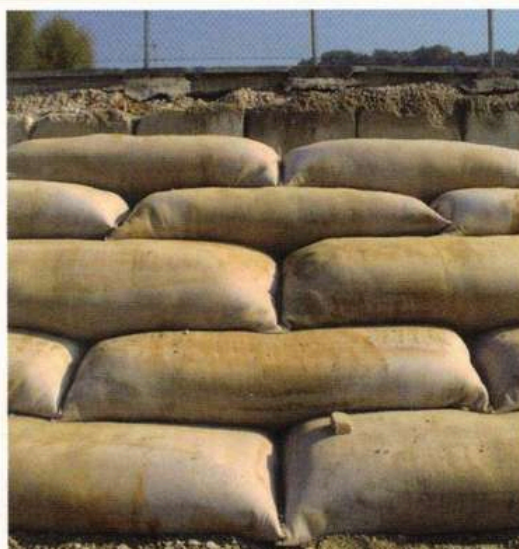

Geo Bags

Installation Guideline



Index

1.0 Installation and personnel	3
2.0 Packaging and Storage	3
3.0 Installation requirements	3
4.0 Filling and laying deck	4
5.0 Weather conditions during installation	4
6.0 Filling operations	5
7.0 Closing the geo bag	7
8.0 Handling and positioning	9
9.0 Maintenance	9
10.0 Repairs	9
11.0 Appendix A	10

1.0 INSTALLATION AND PERSONNEL

All personnel must review these guidelines thoroughly before starting the installation of WavePlus.

It is essential that the installation team fully understands their respective roles and follows the instructions outlined below to ensure optimal results.

For any questions not addressed in this document, please contact SkyTech Engineering for clarification.

2.0 PACKAGING AND STORAGE

WavePlus geo bags are delivered on pallets (Fig. 1) and must be stored indoors to protect them from sunlight and rain.

Non-compliance with these storage guidelines may compromise the material's properties and make handling and filling wet geo bags more challenging.



Fig. 1

3.0 INSTALLATION REQUIREMENTS

At least the following equipment is required in order to ensure proper filling and installation of WavePlus:

1. A loader or excavator with an operator is required, appropriately sized and equipped with a mixing bucket (Fig. 2). This equipment must ensure safe and efficient filling of the geo bag.
2. When the mixing bucket is fully loaded, the equipment should guarantee that the geotextile container remains stable and securely hooked to both the bucket and the supporting frame (Fig. 3).
3. The mixing bucket should include a hose, such as a transparent polyurethane pipe, to prevent stress on the geo bag liner during the filling process. The hose must be securely clamped to the geo bag and positioned to reach its opening (Fig. 4).
4. If the mixing bucket's volume is smaller than that of the geo bag, an additional loader or excavator will be needed to refill the mixing bucket, which must remain in the filling position throughout the process (Fig. 5).



Fig. 2



Fig. 3



Fig. 4

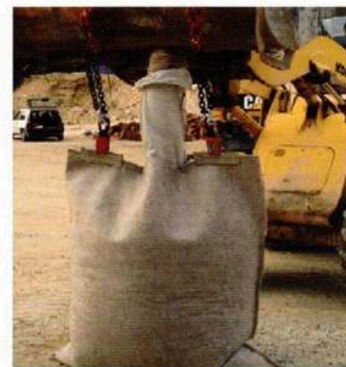

Fig. 5

2 clamps to hold the geo bag (Fig. 6) during filling (e.g. "automatic self-locking clamp with jaws, item 295/SP - manufacturer OMCN", modified as indicated by annex A, in order to ensure a contact surface area of at least 850 sq.cm).

2 adjustable lifting chains connected to the clamps (Fig. 7) with working load of at least 2000 kg;



Fig. 6



Fig. 7

2 hooks to secure the chains with clamps to the mixing bucket (Fig. 8) in steel with diameter of at least 18 mm;



Fig. 8

1 worker plus the operator of the mixing bucket for ground operations.

4.0 FILLING AND LAYING DECK

Clear all debris and shrubs from the work site.

The filling area should be stabilized in order to prevent any possible collapse of the ground during filling; clear sharp debris and shrubs from this area.

5.0 WEATHER CONDITIONS DURING INSTALLATION

Efficient laying may be considerably affected by weather conditions, including tides, waves, wind and rain. Tidal changes may affect the quantity of filling material available, the positioning of the geo bags and working area available, and may damage stored materials and equipment. Strong wave motion may hinder filling and laying operations. When planning installation all the above factors should be taken in order to ensure state-of-the-art laying.

6.0 FILLING OPERATIONS

Before commencing the filling operations, place a stock of sand or gravel close to the filling site.

Once you filled the mixing bucket is necessary to proceed according to the following points:
 1. place the geo bag under the mixing bucket (Fig. 9); attach the geo bag to the bucket (Fig. 10) using the appropriate clamps; fix the internal sleeve of the geo bag to the bucket using a hose clamp with a locking system (Fig. 11); the empty geo bag should not be lifted off the ground.

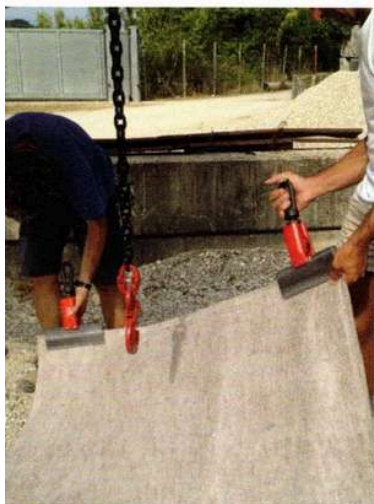

Fig. 9



Fig. 10



Fig. 11

2. fill the geo bag with the inert material (gravel or sand) up to 25-30 cm from the closure (Fig.12); during filling, the operator of the excavator (loader) will have to be careful to put down the mixing bucket to accommodate the height reduction of the geo bag and avoid dangerous stresses of the geo bag; the sleeve must never be stressed.

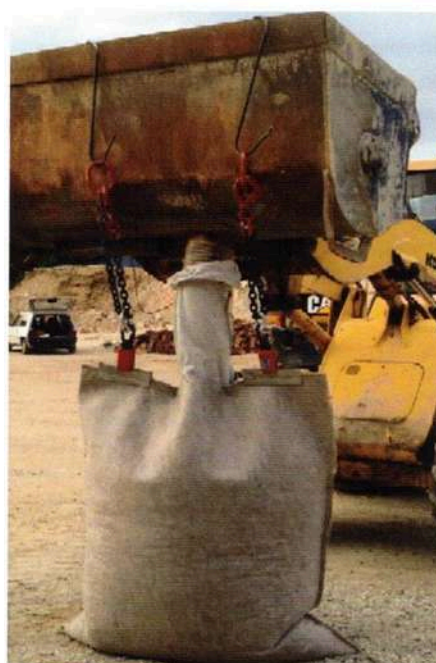

Fig. 12

3. once filled, remove the sleeve from the hose (Fig. 13) and fold it back into the geo bag (Fig. 14);



Fig. 13



Fig. 14

4. proceed with the geo bag closing with a rope (Fig. 15) or with a manual sewing machine (Fig. 16).

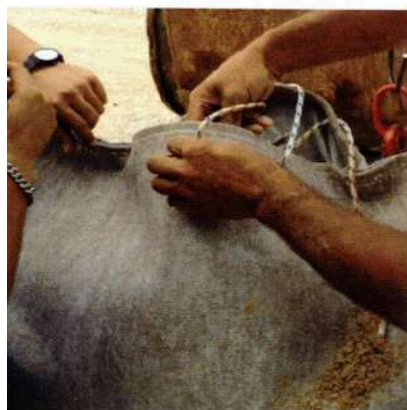

Fig. 15



Fig. 16

5. lay the geo bag on one side and remove it from the clamps of the mixing bucket (Fig. 17).



Fig. 17

Funnel with Scaffolding Arrangement

- A steel funnel will be positioned securely at the designated filling area.
- Geo Bags will be suspended at the funnel mouth using the provided lifting loops.
- Sand will be filled into the Geo Bags using an excavator bucket.
- A high-pressure water line will be used as required to dislodge and flush any clogged sand through the funnel into the Geo Bag.
- The Geo Bag mouth will then be closed and secured using the stitched lacing cord.
- Filled Geo Bags will be lifted using approved lifting belts and transported to the beachside loading bay.



7.0 CLOSING THE GEOBAG

Remove the filling sleeve from the mixing bucket, folding it into the opening of the geo bag. Place the flaps together and close with the cord or machine (Fig. 18 and 19). Only the cord recommended by SkyTech should be used. Before use, ensure that the cord is not tangled and that there are no obvious signs of damage or tearing. The closing knot and cord should be of the type indicated by figures 20 and 21. Ensure that the knots are firmly secured and the cord is well stretched.



Fig. 18



Fig. 19



Fig. 20 A

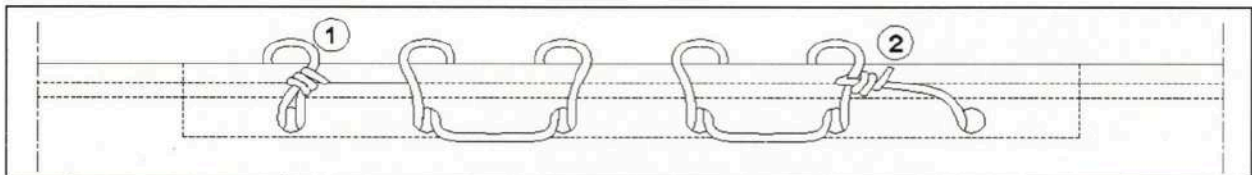

Fig. 20 B

Follow steps (A) to (D) as shown by figure 21. The details of knots (1) and (2) are shown by figures 22 and 23.

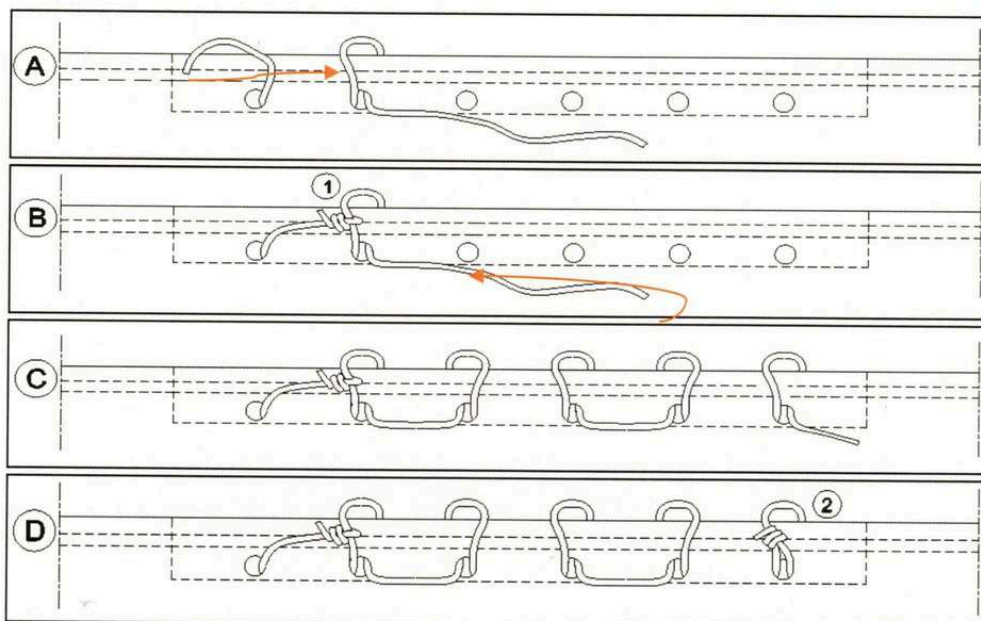

Fig. 21

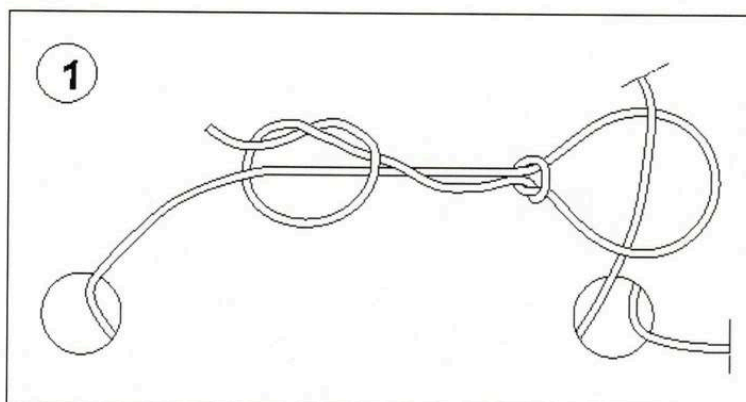

Fig. 22

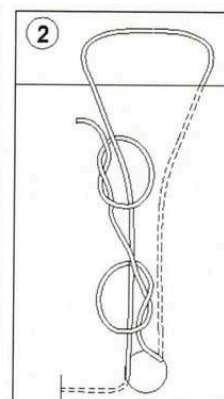

Fig. 23

CLOSING WITH MANUAL SEWING MACHINE

The seam must be performed at 5 cm from the edge (Fig. 25).

Once the geo bag has been stitched, tie with a double knot single both ends of the seam surplus.



Fig. 24



Fig. 25

8.0 HANDLING AND POSITIONING

WavePlus must be handled with an excavator whose dimensions and weight are suitable for lifting geotextile containers, equipped with bucket or hydraulic clamp with flat grab whose dimensions hold at least 80% of the geo bag (Fig. 26 and 27). Belts may also be used (at least two), positioning the same so as to distribute the weight of the geo bag as uniformly as possible and avoid significant deformations (Fig. 28).



Fig. 26



Fig. 27



Fig. 28

The filled geotextile containers should be stored on a perfectly smooth, soft surface and should not be stacked, so as to make it possible to pick up the geo bags with the excavator without damaging them (Fig. 29)

The geo bags should be positioned as instructed by the project engineer, so that the closed side of the seam is in contact with another geo bag (Fig. 30).



Fig. 29



Fig. 30

9.0 MAINTENANCE

Once the structure with the geotextile containers has been completed, the customer is responsible for the routine maintenance of the structure. This requires regular inspections to identify and repair any damage that may occur. The structure should be inspected at least once a month.

10.0 REPAIRS

If the surface of the geo bag is torn, repair the tear only with the patches supplied by SkyTech (Fig. 31-34). Follow these steps: a. clean the area, removing sand and sharp debris from the surface; b. apply a coating of silicone-based glue (such as LOCTITE® SI 5970 or similar): using the dispenser, apply the glue around the damaged area for a distance of about 3 cm around the tear; c. cut out a patch that projects at least 3 cm from the glue area; d. fix the patch to the surface using self-tapping stainless steel A ISI 304 screws, at least 2 cm from the outer edge of the patch. Leave a space of no more than 5 cm between the screws;

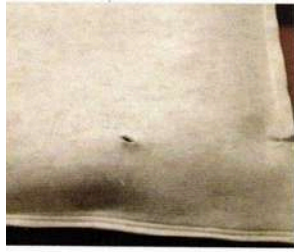

Fig. 31

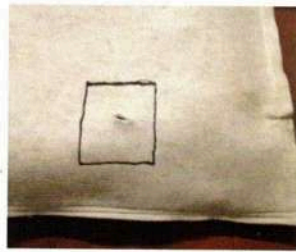

Fig. 32

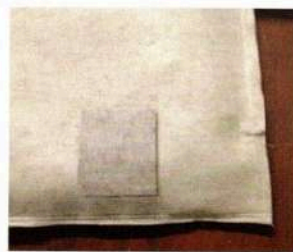

Fig. 33

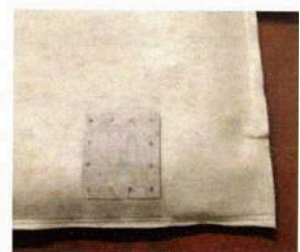

Fig. 34

Only the type of screws, glue and dispenser recommended by SkyTech should be used. Do not move the repaired geotextile container for at least 24 hours after applying the glue.

APPENDIX A - EXAMPLE OF GEOBAG LIFTING CLAMP

Standard clamp before modification.



Type diagram of jaw applied to clamp to increase the gripping surface (dimensions in mm).

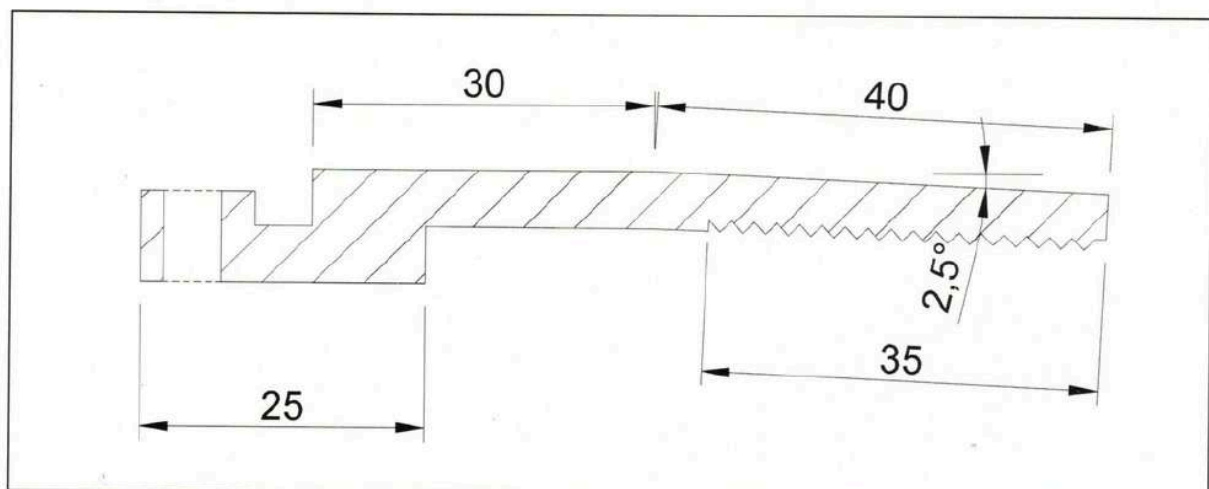

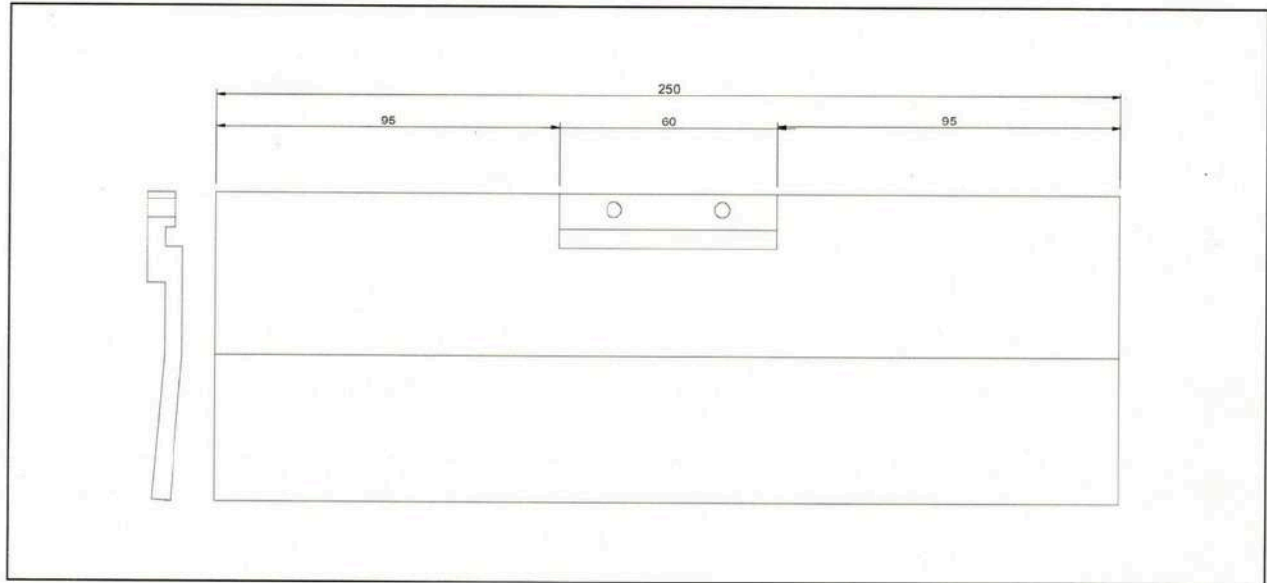

Standard clamp after modification.

